

alpin

T U B E L E S S W H E E L S

alpina

INDICE / INDEX

Photogallery

Team and sponsoring

Supermoto area – ruote complete tubeless a-system

Sm area – complete wheels tubeless a-system

Naked area – ruote complete tubeless a-system

Naked area – complete wheels tubeless a-system

Cross area – ruota tubeless multiuso / 3 in 1

Mx area – complete tubeless wheels multitype

Enduro area – ruota tubeless multiuso / 3 in 1

Rx area – complete tubeless wheels multitype

Finiture di serie

Current finishing

Ruote tubeless a-system edizioni speciali

Special edition wheels tubeless a-system

Abs nipples

Caratteristiche principali tubeless a-system

Tubeless a-system leading particulars

Calcolo ad elementi finiti

Fem analysis

Sts tubeless kit

Caratteristiche tecniche principali sts

Standard tubeless system

Sts – standard tubeless system leading technical particulars

News – alpina carbon pro matrix

4

6

8

14

18

22

27

30

38

40

44

46

58

62

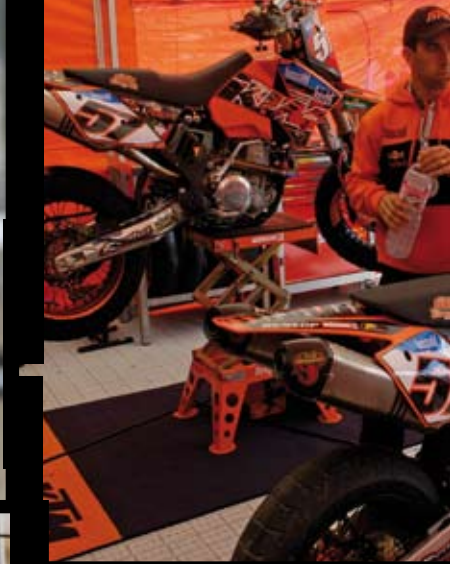

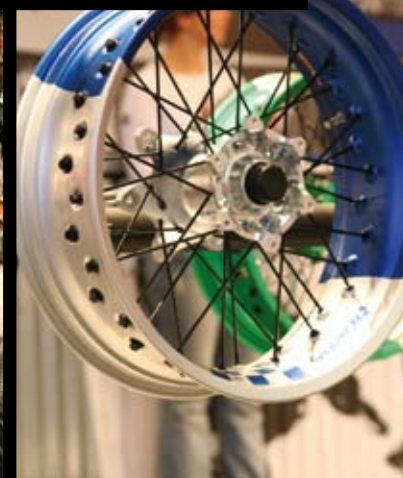

TEAM&Sponsoring_

La passione vera e viscerale verso gli sport motociclistici, e la collaborazione con i professionisti delle competizioni, gli esperti del settore, i piloti e il legame con il mondo a due ruote e a tutti i suoi amanti hanno permesso ad ALPINA di gareggiare in questi anni nelle più importanti competizioni nazionali, europee e mondiali.

Molti piloti hanno gareggiato sudato e vinto sulle nostre ruote tubeless e molti altri ancora lo faranno.

The authentic passion for motorcycle sports, the collaboration with professionals of competitions, experts of this domain, the riders, contacts with the world "on two wheels" and all enthusiasts allowed ALPINA during these years to attend the most important, national, european and international races. Many riders raced and won on our tubeless wheels and many in the future will do.

off road **aprilia****TEAM ITALY SM***SUPERMOTO WORLD CHAMPIONSHIP 07***APRILIA: APRILIA****TEAM AZZALIN: HUSQVARNA****ONLY MOTOR: HONDA****NASTEDO TEAM: KAWASAKI****RIGO MOTO: SUZUKI****TEAM MIGLIO: KTM****MOTORACING DI MOLLO: KTM****TEAM USA SM****MOTOSTRANO: HONDA - SUZUKI - KTM****TEAM USA SM/MX/RX****HART E HUNTINGTON: HONDA - SUZUKI - KTM****HMC: KTM****TEAM USA MX****STAR RACING: YAMAHA****MOTORWORLD: YAMAHA****BBMX: HONDA**



Alpina: Supermoto World Champion 2006 & 2007

RACING PASSION



alpina

07_08

CATALOGUE

SUPERMOTO AREA
COMPLETE WHEELS TUBELESS A-SYSTEM

PRODUCTS AND SYSTEMS PATENTED BY **ALPINA**

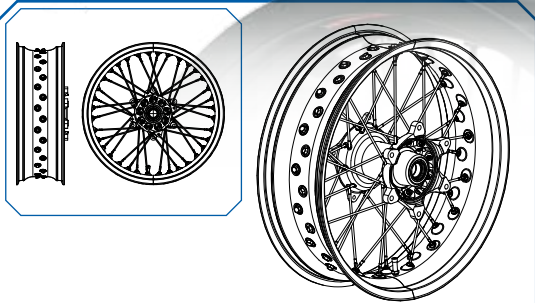

RUOTA ALPINA SERIE TUBELESS SUPERMOTO

SERIE REPLICA TEAM SUPERMOTO

Gamma di ruote SuperMoto realizzate con mozzi dedicati e perfettamente adattabili alle moto standard di serie.

Le ruote Alpina mantengono invariate le posizioni dei cuscinetti e gli alloggiamenti dei dischi freno e della corona. La posizione del cerchio (campanatura) della ruota, è già predisposta per il corretto montaggio da parte dell'utente.

RAGGI Alpina

- In Acciaio Inox alleggeriti - AISI 304
- Realizzati secondo le applicazioni Tubeless (Patented)
- Posteriori: numero 36 \emptyset mm. 4.0 / 3.5 / 4.0
- Anteriori: numero 36 \emptyset mm. 3.5 / 3.0 / 3.5

NIPPLES Alpina

- ABS (Alpina Block System - Patented)
- Prodotti in acciaio con trattamento zinco-cromato

MOZZI Alpina

- In lega d'alluminio ad alta resistenza
- Ricavati dal pieno
- Predisposti per alloggiamento nipples
- Caratterizzati da una finitura sabbziata

CERCHI

Anteriori: 16,5"x3,50" / 17"x3,50"
 Posteriori: 17"x4,25" / 17"x4,50" / 17"x5,00" / 17"x5,50"

I cerchi saranno forniti con una finitura: SABBBIATA e ANODIZZATA

ADATTABILITA' Moto di serie - gamma:

APRILIA, HONDA, HUSQVARNA, KAWASAKI, KTM, SUZUKI, e YAMAHA

ALPINA WHEELS SUPERMOTO TUBELESS SERIES

SUPERMOTO TEAM REPLICA SERIES

Range of SuperMoto wheels realized with special designed hubs - solid piece machined aluminium.

The Alpina wheels maintain unchanged bearings, brake discs and sprocket position.

The wheel alignment, is ready to be correctly mounted by the user.

SPOKES Alpina

- Stainless steel double-buttet spokes for Tubeless application use - AISI 304
- Produced with Tubeless technology (Patented)
- Rear Spokes : 36 spokes, \emptyset mm. 4.0 / 3.5 / 4.0
- Front Spokes: 36 spokes, \emptyset mm. 3.5 / 3.0 / 3.5

NIPPLES Alpina

- ABS (Alpina Block System - Patented)
- Produced with zinc-chrome plated steel

HUB Alpina

Produced in high resistant Aluminium Alloy from a solid piece

The hubs are predisposed for nipples attachments and sand blasted finishing

RIM

Front rim : 16,5"x3,50" / 17"x3,50"
 Rear rim: 17"x4,25" / 17"x4,50" / 17"x5,00" / 17"x5,50"

The rims will be supplied with SAND BLASTED finishing and ANODIZED

WHEEL ADAPTABILITY Standard motorcycles series:

APRILIA, HONDA, HUSQVARNA, KAWASAKI, KTM, SUZUKI E YAMAHA

alpina

ALPINA TUBELESS A-SYSTEM
COMPLETE WHEELS

SUPERMOTO TEAM REPLICA SERIES

SM TUBELESS



* TUBELESS A-SYSTEM - REG.DES. - LE RUOTE ALPINA BICOLOR SONO COPERTE DA UN BREVETTO INTERNAZIONALE SUL DESIGN DELLA DOPPIA COLORAZIONE.





alpina

07_08

CATALOGUE

NAKED AREA
COMPLETE WHEELS TUBELESS A-SYSTEM

PRODUCTS AND SYSTEMS PATENTED BY **ALPINA**

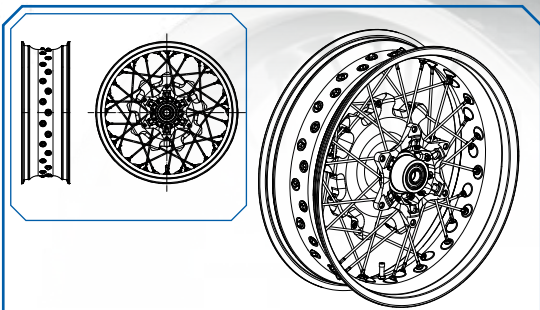

RUOTA ALPINA SERIE TUBELESS NAKED

RUOTA ALPINA A-SYSTEM SERIE NAKED

Le innovative ruote a raggi Alpina senza camera d'aria sono destinate anche all'universo delle moto Naked.

RAGGI Alpina

- In Acciaio Inox - AISI 304
- Realizzati secondo le applicazioni Tubeless (Patented)
- Posteriori: numero 36 ø mm. 4.0
- Anteriori: numero 36 ø mm. 4.0

NIPPLES Alpina

- ABS (Alpina Block System - Patented)
- Prodotti in acciaio con trattamento zinco-cromato

MOZZI Alpina

- In lega d'alluminio
- Ricavati dal pieno
- Predisposti per alloggiamento nipples
- Caratterizzati da una finitura sabbiata

CERCHI

Anteriori: 17"x3,50"
Posteriori: 17"x4,50" / 17"x5,50"

I cerchi saranno forniti con una finitura: SABBIAIA e ANODIZZATA
La doppia colorazione del cerchio è prevista sia nella
uova versione grafica LONGITUDINALE che BICOLOR tradizionale

ADATTABILITA':

DUCATI MONSTER (no monobraccio) / PAUL SMART / SPORT 1000 / SPORT 1000S / GT 1000
HONDA HORNET / BUELL / GUZZI V11

*Tutte le ruote Alpina Tubeless A-System –Serie NAKED – sono dotate di specifico alloggiamento per parastrappi originali e mantengono gli ancoraggi dei dischi freno di serie

ALPINA WHEELS NAKED TUBELESS SERIES

ALPINA A-SYSTEM WHEEL NAKED SERIES

The innovative Alpina Tubeless A-System spoked wheels are available also for Naked Motorcycles.

SPOKES Alpina

- Stainless steel double-buttet spokes for Tubeless application use – AISI 304
- Produced with Tubeless technology (Patented)
- Rear Spokes : 36 spokes, Ø mm. 4.0
- Front Spokes: 36 spokes, Ø mm. 4.0

NIPPLES Alpina

- ABS (Alpina Block System Patented)
- Produced with zinc-chrome plated steel

HUB Alpina

Produced in high resistant Aluminium Alloy from a solid piece
The hubs are predisposed for nipples attachments and sand blasted finishing
Realized with a radial assembly

RIM

Front rim: 17"x3,50"
Rear rim: 17"x4,50" / 17"x5,50"

The rims will be supplied with SAND BLASTED finishing and ANODIZED
The rims will be available both in the double coloured longitudinal version
and traditional bicolor

ADAPTABILITY:

DUCATI MONSTER (no single swingarm) / PAUL SMART / SPORT 1000 / SPORT 1000S / GT 1000
HONDA HORNET / BUELL / GUZZI V11

*All the Alpina Tubeless A-System wheels Naked Series are produced with a special slot allowing to use the standard cush-drive rubber and maintaining the same attachments for the standard brake discs



alpina

07_08

CATALOGUE

CROSS 3 IN 1 AREA
COMPLETE TUBELESS WHEELS MULTITYPE

PRODUCTS AND SYSTEMS PATENTED BY **ALPINA**

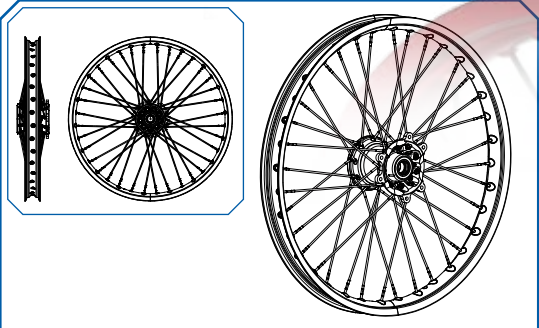

RUOTA ALPINA SERIE CROSS MULTIUSO

La ruota Tubeless Multiuso 3 in 1 di Alpina è montata con pneumatici tubeless e nasce senza camera d'aria. Questa ruota è dotata di 2 fori valvola in posizione diametralmente opposta. Questa particolarità fa aumentare le possibilità di utilizzo della ruota, in quanto si può decidere di utilizzare:

1) IL SISTEMA TUBELESS

La ruota monterà effettivamente 2 valvole

2) LA CAMERA D'ARIA

Utilizzando un foro per il passaggio della valvola della camera d'aria e l'altro per l'eventuale fermacopertone

3) LA MOUSSE

I due fori possono alloggiare opportunamente uno o due fermacopertoni

I CERCHI SONO CARATTERIZZATI DA UN DISEGNO RIVOLUZIONARIO:

PROFILO ARROTONDATO

limita gli accumuli di fango sui bordi preservando le caratteristiche di leggerezza e maneggevolezza durante gare con terreno "pesante" o "bagnato".

CANALE CON GOLA PROFONDA

il profilo interno (specifico per il tubeless) richiede una gola più profonda del consueto. Questa variante incrementa notevolmente la resistenza del cerchio alle sollecitazioni di compressione.

PROFILO CON DOPPIO HUMP

i cerchi sono provvisti di labbro (il così detto hump) che provvede a trattenere in sede con precisione il tallone della copertura. La deformazione della copertura in esercizio è più regolare.

RAGGI Alpina

- In Acciaio Inox – AISI 304
- Posteriori: numero 36, Ø mm. 4.0 / 3.5 / 4.0
- Anteriori: numero 36, Ø mm. 3.5 / 3.0 / 3.5

NIPPLES Alpina

- ABS (Alpina Block System - Patented)
- Prodotti in acciaio con trattamento zinco-cromato

MOZZI Alpina

- In lega d'alluminio
- Ricavati dal pieno
- Predisposti per alloggiamento nipples
- Caratterizzati da una finitura sabbata

CERCHI CROSS

Anteriori: 21" x 1.6"
Posteriori: 19" x 2,15"
I cerchi saranno forniti con una finitura: SABBATA e ANODIZZATA

ADATTABILITA'

Moto di serie – gamma: APRILIA, HONDA, HUSQVARNA, KAWASAKI, KTM, SUZUKI e YAMAHA

ALPINA WHEELS CROSS MULTITYPE SERIES

The Alpina Tubeless Multi-type wheel "three in one" is mounted with tubeless tyres and is born without inner tube. This wheel has two valve holes situated in diametrically opposed position. This particular detail raises the applicability of the wheel, because it gives the possibility to decide between the use of:

1) THE TUBELESS SYSTEM:

the wheel will have two valve holes

2) THE INNER TUBE:

One hole is for the valve of the inner tube and one for the rim-lock

3) MOUSSE

The two valve holes for one or two rim-locks

THE RIMS ARE CHARACTERIZED BY A REVOLUTIONARY DESIGN

ROUNDED PROFILE

Prevents from accumulation of mud on the borders, maintaining its characteristics of easy handling during the races with heavy and wet ground.

DEEP CHANNEL

The inner profile (specific for tubeless) needs a deeper channel as usual. This option increases considerably the rim resistance caused by compression.

PROFILE WITH DOUBLE HUMP

The rims are equipped with a "hump" that ensures to keep the bead of the tyre accurately fitted. The tyre deformation during its use is more regular.

Alpina SPOKES

- Stainless steel AISI 304
- Rear: 36 spokes, Ø mm. 4.0 / 3.5 / 4.0
- Front: 36 spokes, Ø mm. 3.5 / 3.0 / 3.5

Alpina NIPPLES

- ABS (Alpina Block System - Patented)
- Steel with zinc chrome-plated surface treatment

Alpina HUBS

- made of aluminium alloy
- from a solid piece
- Provided to contain the nipples
- With sand-blasted surface

CROSS RIMS

- Front: 21" x 1.6"
- Rear: 19" x 2,15"
The rims are supplied with sand-blasted and anodized surface treatment

ADAPTABILITY

Series production for motorcycles – product range APRILIA, HONDA, HUSQVARNA, KAWASAKI, KTM, SUZUKI e YAMAHA



alpina

07_08

CATALOGUE

ENDURO 3 IN 1 AREA
COMPLETE TUBELESS WHEELS MULTITYPE

PRODUCTS AND SYSTEMS PATENTED BY **ALPINA**

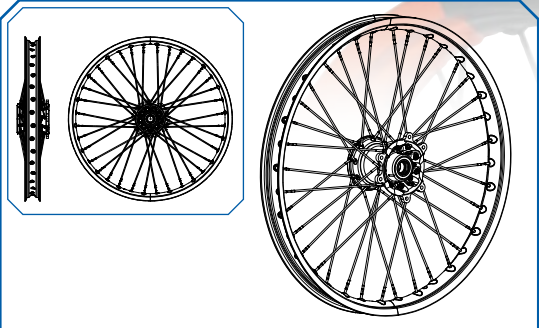

RUOTA ALPINA SERIE ENDURO MULTIUSO

La ruota Tubeless Multiuso 3 in 1 di Alpina è montata con pneumatici tubeless e nasce senza camera d'aria. Questa ruota è dotata di 2 fori valvola in posizione diametralmente opposta. Questa particolarità fa aumentare le possibilità di utilizzo della ruota, in quanto si può decidere di utilizzare:

1) IL SISTEMA TUBELESS

La ruota monterà effettivamente 2 valvole

2) LA CAMERA D'ARIA

Utilizzando un foro per il passaggio della valvola della camera d'aria e l'altro per l'eventuale fermacopertone

3) LA MOUSSE

I due fori possono alloggiare opportunamente uno o due fermacopertoni

I CERCHI SONO CARATTERIZZATI DA UN DISEGNO RIVOLUZIONARIO:

PROFILO ARROTONDATO

limita gli accumuli di fango sui bordi preservando le caratteristiche di leggerezza e maneggevolezza durante gare con terreno "pesante" o "bagnato".

CANALE CON GOLA PROFONDA

il profilo interno (specifico per il tubeless) richiede una gola più profonda del consueto. Questa variante incrementa notevolmente la resistenza del cerchio alle sollecitazioni di compressione.

PROFILO CON DOPPIO HUMP

i cerchi sono provvisti di labbro (il così detto hump) che provvede a trattenere in sede con precisione il tallone della copertura. La deformazione della copertura in esercizio è più regolare.

RAGGI Alpina

- In Acciaio Inox – AISI 304
- Posteriori: numero 36, Ø mm. 4.0 / 3.5 / 4.0
- Anteriori: numero 36, Ø mm. 3.5 / 3.0 / 3.5

NIPPLES Alpina

- ABS (Alpina Block System - Patented)
- Prodotti in acciaio con trattamento zinco-cromato

MOZZI Alpina

- In lega d'alluminio
- Ricavati dal pieno
- Predisposti per alloggiamento nipples
- Caratterizzati da una finitura sabbata

CERCHI ENDURO

Anteriori: 21" x 1.6"
Posteriori: 18" x 2,15"
I cerchi saranno forniti con una finitura: SABBATA e ANODIZZATA

ADATTABILITA'

Moto di serie – gamma: APRILIA, HONDA, HUSQVARNA, KAWASAKI, KTM, SUZUKI e YAMAHA

ALPINA WHEELS ENDURO MULTITYPE SERIES

The Alpina Tubeless Multi-type wheel "three in one" is mounted with tubeless tyres and is born without inner tube. This wheel has two valve holes situated in diametrically opposed position. This particular detail raises the applicability of the wheel, because it gives the possibility to decide between the use of:

1) THE TUBELESS SYSTEM:

the wheel will have two valve holes

2) THE INNER TUBE:

One hole is for the valve of the inner tube and one for the rim-lock

3) MOUSSE

The two valve holes for one or two rim-locks

THE RIMS ARE CHARACTERIZED BY A REVOLUTIONARY DESIGN

ROUNDED PROFILE

Prevents from accumulation of mud on the borders, maintaining its characteristics of easy handling during the races with heavy and wet ground.

DEEP CHANNEL

The inner profile (specific for tubeless) needs a deeper channel as usual. This option increases considerably the rim resistance caused by compression.

PROFILE WITH DOUBLE HUMP

The rims are equipped with a "hump" that ensures to keep the bead of the tyre accurately fitted. The tyre deformation during its use is more regular.

Alpina SPOKES

- Stainless steel AISI 304
- Rear: 36 spokes, Ø mm. 4.0 / 3.5 / 4.0
- Front: 36 spokes, Ø mm. 3.5 / 3.0 / 3.5

Alpina NIPPLES

- ABS (Alpina Block System - Patented)
- Steel with zinc chrome-plated surface treatment

Alpina HUBS

- made of aluminium alloy
- from a solid piece
- Provided to contain the nipples
- With sand-blasted surface

ENDURO RIMS

- Front: 21" x 1.6"
- Rear: 18" x 2,15"
The rims are supplied with sand-blasted and anodized surface treatment

ADAPTABILITY

Series production for motorcycles – product range APRILIA, HONDA, HUSQVARNA, KAWASAKI, KTM, SUZUKI e YAMAHA



SONO DISPONIBILI SUL MERCATO LE COPERTURE TUBELESS DA MOTOCROSS & ENDURO PRODOTTE DA DUNLOP E GOLDENTYRE

TUBELESS TYRES FOR MOTO CROSS & ENDURO PRODUCED BY DUNLOP AND GOLDENTYRE ARE AVAILABLE ON THE MARKET



Gomma GoldenTyre Tubeless - Tyre GoldenTyre Tubeless



Gomma Dunlop Tubeless - Tyre Dunlop Tubeless





COLORI & COMBINAZIONI

COLOURS & COMBINATIONS

COLORI e COMBINAZIONI

COLOUR & COMBINATIONS

CERCHIO / RIM	RAGGI / SPOKES	MOZZO / HUB	COMBINAZIONI / COMBINATIONS
 <p>ARGENTO / SILVER ROSSO / RED</p>	 <p>ARGENTO / SILVER</p>	 <p>ROSSO / RED</p>	<p><i>Colorazione proposta per ruote dedicate alle moto di serie: "APRILIA" (cross/enduro/sm)</i></p> <p><i>Colouring proposed for wheels dedicated to standard motorcycle series: "APRILIA" (cross/enduro/sm)</i></p>
 <p>NERO / BLACK VERDE / GREEN</p>	 <p>NERO / BLACK</p>	 <p>VERDE / GREEN</p>	<p><i>Colorazione proposta per ruote dedicate alle moto di serie: "KAWASAKI" (cross/enduro/sm)</i></p> <p><i>Colouring proposed for wheels dedicated to standard motorcycle series: "KAWASAKI" (cross/enduro/sm)</i></p>
 <p>NERO / BLACK GIALLO / YELLOW</p>	 <p>NERO / BLACK</p>	 <p>GIALLO / YELLOW</p>	<p><i>Colorazione proposta per ruote dedicate alle moto di serie: "SUZUKI" (cross/enduro/sm)</i></p> <p><i>Colouring proposed for wheels dedicated to standard motorcycle series: "SUZUKI" (cross/enduro/sm)</i></p>
 <p>ARGENTO / SILVER BLU / BLUE</p>	 <p>ARGENTO / SILVER</p>	 <p>BLU / BLUE</p>	<p><i>Colorazione proposta per ruote dedicate alle moto di serie: "YAMAHA" (cross/enduro/sm)</i></p> <p><i>Colouring proposed for wheels dedicated to standard motorcycle series: "YAMAHA" (cross/enduro/sm)</i></p>

* I Cerchi possono essere richiesti in altre combinazioni di colori * Tutti i mozzi monocolor sono abbinabili ai cerchi bicolor richiesti
 * The rims can be supplied with other colour combinations * All the hubs can be combined with the requested double colour rims

CERCHIO / RIM		RAGGI / SPOKES	MOZZO / HUB	COMBINAZIONI / COMBINATIONS
				<p>Colorazione proposta per ruote dedicate alle moto di serie: "KTM" (cross/enduro/sm)</p> <p>Colouring proposed for wheels dedicated to standard motorcycle series: "KTM" (cross/enduro/sm)</p>
ARANCIO / ORANGE	NERO / BLACK	NERO / BLACK	ARANCIO / ORANGE	
				<p>Colorazione proposta per ruote dedicate alle moto di serie: "HONDA" (cross/enduro/sm)</p> <p>Colouring proposed for wheels dedicated to standard motorcycle series: "HONDA" (cross/enduro/sm)</p>
ROSSO / RED	NERO / BLACK	NERO / BLACK	ROSSO / RED	
				<p>Colorazione proposta per ruote dedicate alle moto di serie: "HUSQVARNA" (cross/enduro/sm)</p> <p>Colouring proposed for wheels dedicated to standard motorcycle series: "HUSQVARNA" (cross/enduro/sm)</p>
GIALLO / YELLOW	BLU / BLUE	NERO / BLACK	BLU / BLUE	
				<p>Colorazione proposta per ruote dedicate AREA NAKED TUBELESS*</p> <p>Colouring proposed for NAKED TUBELESS AREA wheels*</p>
ARGENTO / SILVER / NERO/BLACK - ARGENTO / SILVER	ARGENTO / SILVER	NERO / BLACK	ARGENTO / SILVER	
				<p>Colorazione proposta per ruote dedicate AREA NAKED TUBELESS*</p> <p>Colouring proposed for NAKED TUBELESS AREA wheels*</p>
ARGENTO / SILVER / NERO/BLACK - ARGENTO / SILVER	ARGENTO / SILVER	NERO / BLACK	NERO / BLACK	

* Disponibili anche nella versione Bicolor tradizionale / Also available in traditional two tones version





alpinag

07_08
CATALOGUE

SPECIAL edition
COMPLETE WHEELS TUBELESS A-SYSTEM

PRODUCTS AND SYSTEMS PATENTED BY **ALPINA**

SPECIAL edition



Ratoo wheels



SPECIAL edition



Tato wheels



TUBELESS A-SYSTEM

alpina

07_08

CATALOGUE

Tubeless A-System
TECHNICAL details

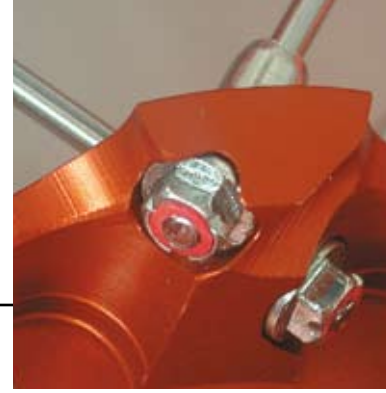

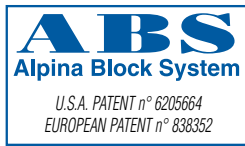

Alpina Block System

Nipples autobloccanti, cioè dotati di una coppia frenate antisvitamento, generata dall'interferenza tra il filetto del raggio e l'anellino di Nylon all'interno dei nipples.

Durante l'esercizio la ruota si "muove" causando dei cali di tensionamento dei raggi rendendo instabile l'accoppiamento raggio/nipplo.

Il sistema ABS impedisce questo inconveniente consentendo alla ruota di rimanere centrata e tensionata nel tempo.

Il sistema ABS è utilizzato da anni con successo nel settore ciclo.

Alpina Block System

Self blocking, means a kind of nipple that also without a pre-load generated by the interference between the threaded spoke border and the nylon ring inserted in the nipple itself, has an unscrewable braking couple.

The wheel is moving. This movement creates some loss in the spoke tension and this phenomenon destabilises the spoke/nipple connection (if the nipples is un-loaded it can be unscrewed).

Since years the ABS system is successfully used in the bicycle sector.

Il sistema



CARATTERISTICHE PRINCIPALI

TUBELESS A-SYSTEM

È un'innovativa ruota raggiata priva di camera d'aria, capace di utilizzare la tecnologia tubeless, e conseguentemente gode dei benefici di sicurezza tipici dei sistemi antiforatura.

Il Prodotto è destinato ad un uso agonistico e conseguentemente non si presta ad essere utilizzato su strada pubblica.

Il suo rivoluzionario sistema di sigillatura ermetica dei fori nel cerchio e l'utilizzo di un terminale solidale con guarnizione, garantisce l'assenza assoluta di trafilature d'aria durante l'utilizzo della ruota. Il cerchio è forato tradizionalmente, ma i fori sono orientati con una certa precisione e filettati.

All'interno del foro filettato s'impegna un terminale provvisto di guarnizione. Il raggio è trattenuto dal terminale con un vincolo a ginocchiera, mentre nel mozzo trova alloggiamento il nipplo ABS (Alpina Block System)*

La ruota di casa Alpina grazie alla sua fitta

raggiatura che collega mozzo e cerchio, permette un'ottima distribuzione dei carichi, quindi in caso di rottura di uno o più raggi il suo funzionamento non è compromesso.

L'assenza della forte rigidità tipica delle ruote integrali, permette inoltre alla ruota TUBELESS A-SYSTEM di sopportare forti sollecitazioni, passando senza problemi da una guida su strada ad un percorso fuoristrada, un ulteriore vantaggio che alza la qualità delle insostituibili ruote a raggi e libera tutte le potenzialità prestazionali delle coperture.

ALPINA propone una novità assoluta nel mondo Supermotard, una generazione di ruote estreme e dal design accattivante, capaci di migliorare le prestazioni di SICUREZZA, PERFORMANCE e UTILIZZO del mezzo.

Le ruote Alpina sono realizzate esclusivamente con "mozzi ricavati dal pieno"



- CRESCE LA RESISTENZA ALLA FORATURA
- AUMENTANO PERFORMANCE E MANEGGEVOLEZZA
- DIMINUISCE IL PESO DELLA MASSA ROTANTE
- SOPPORTA FORTI SOLLECITAZIONI
- ELIMINA GLI SVANTAGGI CAUSATI DA UN'ECESSIVA RIGIDITA'
- SI RIDUCE ENORMEMENTE IL CONSUMO DEI PNEUMATICI

The System



LEADING PARTICULARS

A-System by Alpina is an innovative Tubeless Spoked Wheel.

This revolutionary system consists of hermetically sealing the holes within the rim. Moreover the use of a terminal with gasket, guarantees the complete absence of air strain during the normal use of the wheel.

The rim is traditionally hole punched, but in the case of A-System by Alpina the holes are oriented in a particular direction and are also threaded. A terminal with gasket is inserted into the threaded hole.

The spoke is held by the terminal through a toggle joint and the ABS (Alpina Block System) nipple is based in the hub.

The Alpina wheel, thanks to its close-knit spokes

connects the hub and the rim, and allows an optimum load distribution.

Should a spoke break the wheel will still continues to work. The flexibility of the tubeless A-System in contrast to integral wheels means any kind of impact can be absorbed.

This means A-System wheels are particularly suitable for cross country and road riding races. They also improve tyre performance. Alpina is now launching an innovation in the SUPERMOTO world, a generation of extreme wheels created with a futuristic design.

These new wheels have enhanced the performance, the safety and the use itself of the bike.

The wheels are supplied with hubs made of high resistant Aluminium Alloy and made of a solid piece.



- BY IMPROVING THE PUNCTURE RESISTANCE
- BY INCREASING THE MANAGEABILITY OF THE BIKE
- BY LOWERING THE WEIGHT OF THE ROTATING BULK
- BY COPING WITH HEAVY IMPACT STRESS
- BY REMOVING THE DISADVANTAGES OF GREATER RIGIDITY
- TUBELESS WHEELS GIVE WAY TO A SMOOTHER RIDE AND ENHANCED TYRE PERFORMANCE

VANTAGGI TECNICI

SICUREZZA

- ◆ *Aumenta la resistenza alla foratura*
- ◆ *Viene meno il problema dell'esplosione del pneumatico*
- ◆ *Scompare il problema dei surriscaldamenti dovuti dall'attrito camera/copertura*
- ◆ *La moto è più reattiva e maneggevole*
- ◆ *In caso di rotazione della copertura sul cerchio non vi è pericolo di strappare la valvola*
- ◆ *La ruota raggiata è indistruttibile ed è in grado di subire forti sollecitazioni senza cedere*

SCORREVOLEZZA

- ◆ *Si elimina la dispersione di energia causata dall'attrito tra camera d'aria e copertura*

PESO/MANEGGEVOLEZZA

- ◆ *La scomparsa delle camere d'aria consente una perdita di circa 1,5 Kg per coppia di ruote*
- ◆ *Grazie all'eliminazione di una massa periferica della ruota, la "MASSA ROTANTE" è ridotta e ciò permette di ottimizzare accelerazione, frenata e maneggevolezza del mezzo*

UTILIZZO

- ◆ *Viene esaltata la potenzialità della copertura grazie all'assente rigidità della camera d'aria e del calore generato localmente dagli attriti camera/copertura*
- ◆ *Le basse pressioni - molto apprezzate nei fuoristrada per migliorare il grip - diventano più facili da gestire poiché la copertura è molto più libera di deformarsi ciclicamente e senza controindicazioni*
- ◆ *Attraverso l'eliminazione dei fori aperti di passaggio nipplo nel cerchio, è inibita la possibilità che acqua e sporco possano essere centrifugati all'interno della ruota, tra cerchio e camera d'aria*

MANUTENZIONE

- ◆ *Esente da manutenzioni straordinarie, salvo la sostituzione della copertura usurata o delle normali registrazioni di centratura*
- ◆ *Il montaggio e lo smontaggio della copertura è facilitato e reso sicuro*
- ◆ *Non esistono più parti facilmente danneggiabili*

The System



TECHNICAL ADVANTAGE

SAFETY

- ◆ *Increases puncture resistance*
- ◆ *Tyre explosion is minimized*
- ◆ *Overheating damage, due to friction between inner tube and cover tyre, is eliminated*
- ◆ *Better managability*
- ◆ *Spoked wheels are indestructible and able to cope with heavy impact stress without bending*
- ◆ *Cover rotation on the rim creates no danger of valve being ripped out*

SMOOTHNESS OF THE RIDE

- ◆ *No dispersion of energy –caused by inner tube cover tyre friction*

WEIGHT/RIDER HANDINESS

- ◆ *The absence of the tubes, allows a loss of weight of about 1,5 Kg for each wheel set*
- ◆ *The rotating bulk is reduced due to the elimination of peripheral wheel bulk. This optimizes the acceleration and both the rider handiness and the brake system*

USE

- ◆ *The tyre potential power is highlighted by the absence of rigidity in the tube, and the heat locally generated by the friction between the tube and the cover tyre*
- ◆ *Low pressure, very much appreciated in cross-country races optimizes the grip, therefore improving the managability of the cover tyre positioned between the rim and the outer tyre*
- ◆ *The shape then adjusts according to the road conditions, without added precautions*
- ◆ *The tyre is completely sealed, allowing no water or dirt to get in*

MAINTENANCE

- ◆ *The wheel doesn't require any particular maintenance, except the usual balance wheel register and tyre substitution*
- ◆ *There are no longer any easily damageable parts*
- ◆ *The mounting and removal of the tyres, is safer and more practical*
- ◆ *The tyre wear is hugely reduced*

TUBELESS  **-SYSTEM**

MODELLO 3D / 3D MODEL

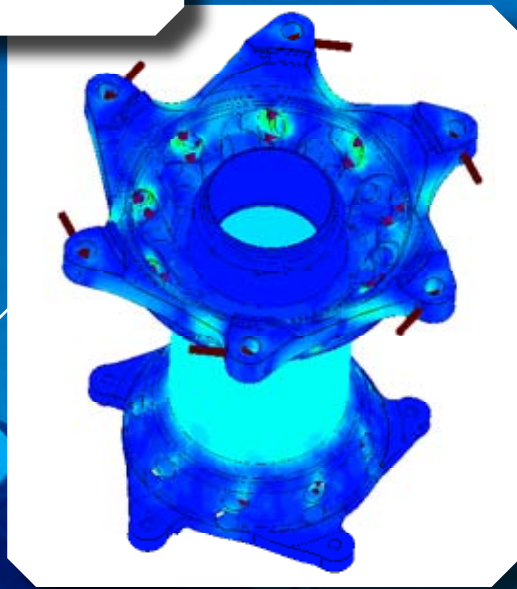
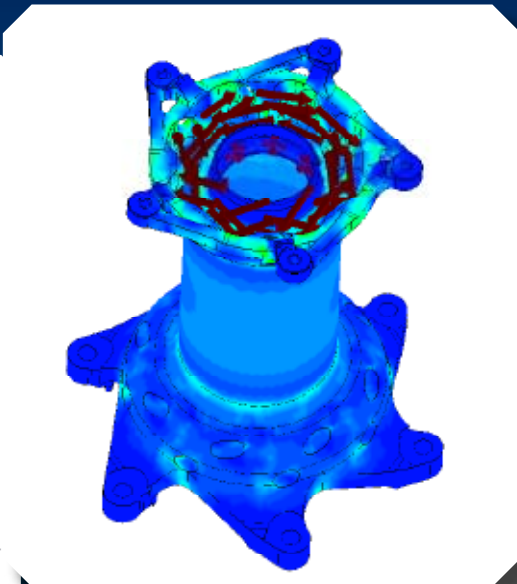

CALCOLO AD ELEMENTI FINITI

La progettazione e il dimensionamento dei componenti della ruota, quali i mozzi ed i raggi, viene supportata dal calcolo strutturale mediante l'utilizzo di programmi dedicati all'analisi ad elementi finiti (FEA).

L'obiettivo è di ottimizzare il prodotto garantendone la piena funzionalità e sicurezza.

Nelle analisi condotte vengono simulate le condizioni di carico a cui sono soggetti i diversi componenti della ruota nelle varie condizioni di funzionamento e montaggio, in modo da valutare eventuali modifiche da apportare al progetto per migliorare il prodotto.

FINITE ELEMENTS ANALYSIS

The wheel components design and measurements (spokes & hubs) are realized by using programs specifically dedicated to the finite elements analysis (FEA).

The aim of these programs are to optimize each product, guaranteeing its whole functionality and safety.

During this kind of analysis, take place the simulation of some stress-load conditions typical of the mounting and functioning setting of the product itself. The result of this studying process is to improve the product features, evaluating the possibility to make changes into the technical project.





alpina

07_08

CATALOGUE

alpina TUBELESS STS
Kit Tubeless STS

PRODUCTS AND SYSTEMS PATENTED BY **ALPINA**

Il sistema STS - standard tubeless system viene sviluppato e brevettato da Alpina, allo scopo di rendere TUBELESS le ruote raggiate, in modo ECONOMICO e SICURO.

COME FUNZIONA?

Il sistema STS prevede l'utilizzo di un nipples speciale (STS) munito di una guarnizione che sigilla completamente la naturale fessura esistente fra il foro del cerchio e il nipple stesso.

Il sistema è di successo perché la sua applicazione non prevede sostanziali variazioni nella ruota, che rimarrà concettualmente e strutturalmente identica a quella di serie, infatti il mozzo originale è mantenuto.

Varia con il kit: lunghezza dei raggi - nipples speciale STS - foro del cerchio di dimensione adeguata al diametro del nipples STS

1 KIT PER 3 OPZIONI DI UTILIZZO / LA RUOTA 3 IN 1

Focus: Cross - Enduro

I cerchi del KIT STS hanno 2 fori valvola in posizione diametralmente opposta. Questa particolarità fa aumentare le possibilità di utilizzo della ruota, in quanto si può decidere di utilizzare:

1) Il sistema tubeless

La ruota monterà effettivamente 2 valvole

2) La camera d'aria

Utilizzando un foro per il passaggio della valvola della camera d'aria e l'altro per l'eventuale fermacopertone

3) La mousse

I due fori possono alloggiare opportunamente uno o due fermacopertoni

FRONTIERE DI UTILIZZO

Gli orizzonti del sistema STS sono molteplici, il primo ambiente in cui ha esordito è stato il SUPERMOTARD (campionato del mondo e italiano 2007) ed il MOTOCROSS. Le sue applicazioni sono valide anche per l'area ENDURO & ALLROAD

DA COSA E' COMPOSTO IL KIT?

il KIT ALPINA TUBELESS STS è composto da raggi lisci con finitura ECOZINC O CROMATI (diametro e numero pezzi adeguato al modello di moto a cui il KIT è destinato) + corrispondenti nipples STS con guarnizione preassemblata e ingrassata (pronti al montaggio) + relativi anelli di sicurezza (da assemblare sul nipple a ruota montata).

Il tutto dovrà essere associato al cerchio appositamente forato per accogliere il sistema STS, adatto alla moto da trasformare.

QUANTO E' IL RISPARMIO DI PESO SCEGLIENDO STS?

Il peso del nipples STS supera di poco quello di un tradizionale nipples ma consente di togliere flap, camera, (ed eventualmente ferma copertone per il cross).

il risparmio di peso globale è quindi di circa 600g per la ruota anteriore e 900g per quella posteriore / questo vale sia per il cross - enduro che per il motard - allroad

The STS standard tubeless system is developed and patented by Alpina, for the purpose to find a solution to create a safe and at the same time convenient spoked tubeless wheel.

HOW DOES IT WORK?

The STS system provides the application of a special nipple (STS) with a gasket that seals in a natural way the slot between the rim hole and the nipple.

The system is successful because its application doesn't basically change the wheel, that as concept and structurally is identical with the series wheel, in fact the original hub remains the same

Kit options: spoke length - special STS nipple - rim hole with adequate dimensions for the STS nipple

1 KIT FOR THREE APPLICATIONS THE "THREE IN ONE" WHEEL

Focus: Mx - Rx

The rims of the STS KIT have two valve holes in diametrically opposed position. This particular detail raises the applicability of the wheel, because it gives the possibility to decide between the use of:

1) The tubeless system

The wheel will have 2 valve holes

2) The inner tube

One hole is for the valve of the inner tube and one for the rim-locks (if present)

3) Mousse

The two valve holes for one two rim-locks

APPLICATION SKYLINES

There exist multiple skylines for the STS system: it received its premiere in the SUPERMOTO scene (Italian and world Championship 2007) and MOTOCROSS. Its applications are also valid for the ENDURO&ALLROAD ambience

WHAT DOES THE KIT CONSIST OF?

The ALPINA TUBELESS STS KIT consists of straight spokes with ECOZINC surface treatment or CHROME-PLATED (diameter and number of pieces is adequate to the motorbike for which the KIT is made for) and correspondent STS nipples with pre-assembled and lubricated gasket (ready for assembly) and retaining ring (to assemble on the nipple once the wheel is mounted). All this will go together with the especially drilled rim in order to locate the STS system for the motorbike that is going to be transformed

HOW MUCH IS THE SAVING OF WEIGHT BY CHOOSING THE STS?

The weight of the nipple is a little bit more than of a traditional nipple but it allows to take away the flap, inner tube and eventually the rim-lock for cross use. The saving of the total weight is about 600g for the front wheel and 900g for the rear wheel/ that is valid for the Cross-Enduro-Supermoto-Allroad

alpina TUBELESS STS

- A) Alpina Raggi - Spokes Ecozinc
- B) Nipples Alpina Sts
- C) Anelli di arresto - Retaining Rings

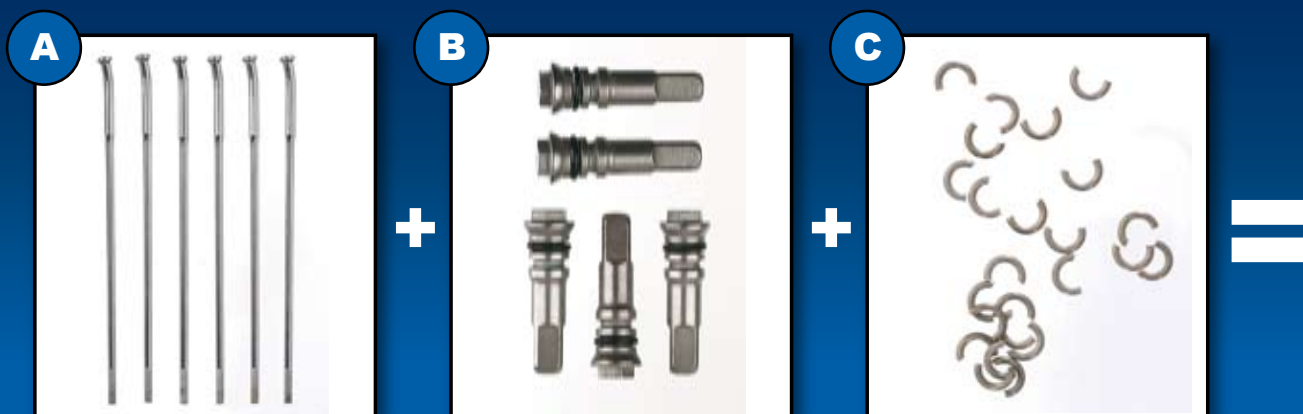

KIT
alpina TUBELESS STS

Optional

CERCHI *



Ex: Model Ktm 990 Adventure



Ex: Model Cross Husqvarna

JACKET BY ALPINA



Yellow



Red



Silver



Black

Jacket in plastica colorati
Finalità: estetica e antipolvere
Jacket coloured plastic
Purpose: aesthetics and dust protection

* Tutti i modelli di cerchio in commercio forati secondo tolleranze e specifiche Alpina (vedi pag. 57). Finitura sabbata/anodizzata nero
* All rim models in trade drilled according to Alpina specifications and tolerances (s. page 57). Surface treatment: sand blasted / black anodized

alping TUBELESS STS

The STS Equation



+



+



+



KIT
alping TUBELESS STS

Original Hubs





Optional

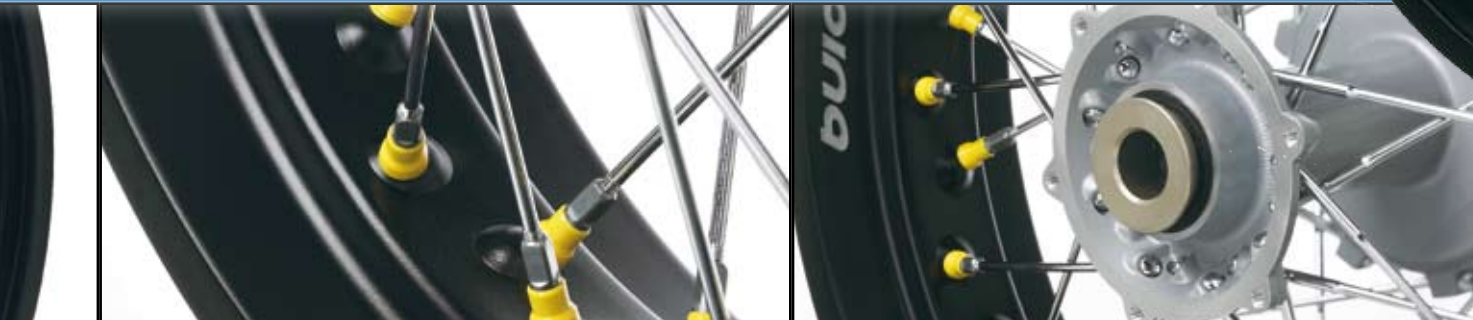

ALPINA STS - CONVERSION TUBELESS KIT CHART

	KAWASAKI		SUZUKI		HONDA		YAMAHA		APRILIA		HUSQVARNA		K T M		TRIUMPH	
	code N°	code N°	code N°	code N°	code N°	code N°	code N°	code N°	code N°	code N°	code N°	code N°	code N°	code N°	code N°	code N°
	KIT STS	RIM	KIT STS	RIM	KIT STS	RIM	KIT STS	RIM	KIT STS	RIM	KIT STS	RIM	KIT STS	RIM	KIT STS	RIM
	spokes&nipples		spokes&nipples		spokes&nipples		spokes&nipples		spokes&nipples		spokes&nipples		spokes&nipples		spokes&nipples	
FRONT CROSS & ENDURO		U7		U0		U8		U0		T6		T4		U0		
	1 KA		8 SU		15 HN		22 YA		29 AP		36 HU		43 KT			
REAR CROSS		U9		V1		U3		V2		T7		T5		V3		
	2 KA		9 SU		16 HN		23 YA		30 AP		37 HU		44 KT			
REAR ENDURO		V4		V5		V6		V7		V8		V9		W1		
	3 KA		10 SU		17 HN		24 YA		31 AP		38 HU		45 KT			
FRONT MOTARD		W2-6		W3-6		W4-6		W3-6		W5-6		S1-6		W3-6		
	4 KA		11 SU		18 HN		25 YA		32 AP		39 HU		46 KT			
FRONT MOTARD		W2-7		W3-7		W4-7		W3-7		W5-7		S1-7		W3-7		
	5KA		12 SU		19 HN		26 YA		33 AP		40 HU		47 KT			
REAR MOTARD		W6-50		W7-50		W8-50		W9-50		X1-50		S2-50		X2-50		
	6 KA		13 SU		20 HN		27 YA		34 AP		41 HU		48 KT			
REAR MOTARD		W6-55		W7-55		W8-55		W9-55		X1-55		S2-55		X2-55		
	6 KA		13 SU		20 HN		27 YA		34 AP		41 HU		48 KT			
FRONT ALLROAD														U1	52 TR	W0
														50 KT	53 TR	X3
REAR ALLROAD														U2	54 TR	X0
														51 KT		

	KAWASAKI		SUZUKI		HONDA		YAMAHA		APRILIA		HUSQVARNA		K T M		TRIUMPH	
	KIT STS	RIM	KIT STS	RIM	KIT STS	RIM	KIT STS	RIM	KIT STS	RIM	KIT STS	RIM	KIT STS	RIM	KIT STS	RIM
	spokes&nipples code N° 1 KA	code N° U7	spokes&nipples code N° 8 SU	code N° U0	spokes&nipples code N° 15 HN	code N° U8	spokes&nipples code N° 22 YA	code N° U0	spokes&nipples code N° 29 AP	code N° T6	spokes&nipples code N° 36 HU	code N° T4	spokes&nipples code N° 43 KT	code N° U0	spokes&nipples	
FRONT	Per Mod. KX-F	Cerchio 217/1,6"	Per Mod. RM-Z	Cerchio 217/1,6"	Per Mod. CR-F	Cerchio 217/1,6"	Per Mod. WR-F e YZ-F	Cerchio 217/1,6"	Per Mod. MXV e RXV	Cerchio 217/1,6"	Per Mod. TC e TE	Cerchio 217/1,6"	Per Mod. SX-F e EXC-F	Cerchio 217/1,6"		
CROSS & ENDURO	36 Raggi D3,5 ecoc zinc	sabbiato anodizzato/nero	36 Raggi D3,5 ecoc zinc	sabbiato anodizzato/nero	36 Raggi D3,5 ecoc zinc	sabbiato anodizzato/nero	36 Raggi D3,5 ecoc zinc	sabbiato anodizzato/nero	36 Raggi D3,5 ecoc zinc	sabbiato anodizzato/nero	36 Raggi D3,5 ecoc zinc	sabbiato anodizzato/nero	36 Raggi D3,5 ecoc zinc	sabbiato anodizzato/nero		
	36 Niplo STS M4.		36 Niplo STS M4.		36 Niplo STS M4.		36 Niplo STS M4.		36 Niplo STS M4.		36 Niplo STS M4.		36 Niplo STS M4.			
REAR	code N° 2 KA	code N° U9	code N° 9 SU	code N° V1	code N° 16 HN	code N° U3	code N° 23 YA	code N° V2	code N° 30 AP	code N° T7	code N° 37 HU	code N° T5	code N° 44 KT	code N° V3		
	Per Mod. KX-F	Cerchio 197/2,15"	Per Mod. RM-Z	Cerchio 197/2,15"	Per Mod. CR-F	Cerchio 197/2,15"	Per Mod. YZ-F	Cerchio 197/2,15"	Per Mod. MXV	Cerchio 197/2,15"	Per Mod. TC	Cerchio 197/2,15"	Per Mod. SX-F	Cerchio 197/2,15"		
CROSS	36 Raggi D4 ecoc zinc	sabbiato anodizzato/nero	36 Raggi D4 ecoc zinc	sabbiato anodizzato/nero	32 Raggi D4 ecoc zinc	sabbiato anodizzato/nero	36 Raggi D4 ecoc zinc	sabbiato anodizzato/nero	36 Raggi D4 ecoc zinc	sabbiato anodizzato/nero	36 Raggi D4 ecoc zinc	sabbiato anodizzato/nero	36 Raggi D4 ecoc zinc	sabbiato anodizzato/nero		
	36 Niplo STS M4,5		36 Niplo STS M4,5		32 Niplo STS M4,5		36 Niplo STS M4,5		36 Niplo STS M4,5		36 Niplo STS M4,5		36 Niplo STS M4,5			
REAR	code N° 3 KA	code N° V4	code N° 10 SU	code N° V5	code N° 17 HN	code N° V6	code N° 24 YA	code N° V7	code N° 31 AP	code N° V8	code N° 38 HU	code N° V9	code N° 45 KT	code N° W1		
	Per Mod. KX-F	Cerchio 187/2,15"	Per Mod. RM-Z	Cerchio 187/2,15"	Per Mod. CR-F	Cerchio 187/2,15"	Per Mod. WR-F	Cerchio 187/2,15"	Per Mod. RXV	Cerchio 187/2,15"	Per Mod. TE	Cerchio 187/2,15"	Per Mod. EXC-F	Cerchio 187/2,15"		
ENDURO	36 Raggi D4 ecoc zinc	sabbiato anodizzato/nero	36 Raggi D4 ecoc zinc	sabbiato anodizzato/nero	32 Raggi D4 ecoc zinc	sabbiato anodizzato/nero	36 Raggi D4 ecoc zinc	sabbiato anodizzato/nero	36 Raggi D4 ecoc zinc	sabbiato anodizzato/nero	36 Raggi D4 ecoc zinc	sabbiato anodizzato/nero	36 Raggi D4 ecoc zinc	sabbiato anodizzato/nero		
	36 Niplo STS M4,5		36 Niplo STS M4,5		32 Niplo STS M4,5		36 Niplo STS M4,5		36 Niplo STS M4,5		36 Niplo STS M4,5		36 Niplo STS M4,5			
FRONT	code N° 4 KA	code N° W2-6	code N° 11 SU	code N° W3-6	code N° 18 HN	code N° W4-6	code N° 25 YA	code N° W3-6	code N° 32 AP	code N° W5-6	code N° 39 HU	code N° S1-6	code N° 46 KT	code N° W3-6		
	Per Mod. CR-F	Cerchio 16,5/3,5"	Per Mod. RM-Z	Cerchio 16,5/3,5"	Per Mod. CR-F	Cerchio 16,5/3,5"	Per Mod. WR-F e YZ-F	Cerchio 16,5/3,5"	Per Mod. SXV	Cerchio 16,5/3,5"	Per Mod. SM	Cerchio 16,5/3,5"	Per Mod. SX-F e EXC-F	Cerchio 16,5/3,5"		
MOTARD	36 Raggi D3,5 ecoc zinc	sabbiato anodizzato/nero	36 Raggi D3,5 ecoc zinc	sabbiato anodizzato/nero	36 Raggi D3,5 ecoc zinc	sabbiato anodizzato/nero	36 Raggi D3,5 ecoc zinc	sabbiato anodizzato/nero	36 Raggi D3,5 ecoc zinc	sabbiato anodizzato/nero	36 Raggi D3,5 ecoc zinc	sabbiato anodizzato/nero	36 Raggi D3,5 ecoc zinc	sabbiato anodizzato/nero		
	36 Niplo STS M4.		36 Niplo STS M4.		36 Niplo STS M4.		36 Niplo STS M4.		36 Niplo STS M4.		36 Niplo STS M4.		36 Niplo STS M4.			
FRONT	code N° 5 KA	code N° W2-7	code N° 12 SU	code N° W3 -7	code N° 19 HN	code N° W4 -7	code N° 26 YA	code N° W3 -7	code N° 33 AP	code N° W5 -7	code N° 40 HU	code N° S1-7	code N° 47 KT	code N° W3-7		
	Per Mod. CR-F	Cerchio 177/3,5"	Per Mod. RM-Z	Cerchio 177/3,5"	Per Mod. CR-F	Cerchio 177/3,5"	Per Mod. WR-F e YZ-F	Cerchio 177/3,5"	Per Mod. SXV	Cerchio 177/3,5"	Per Mod. SM	Cerchio 177/3,5"	Per Mod. SX-F e EXC-F	Cerchio 177/3,5"		
MOTARD	36 Raggi D3,5 ecoc zinc	sabbiato anodizzato/nero	36 Raggi D3,5 ecoc zinc	sabbiato anodizzato/nero	36 Raggi D3,5 ecoc zinc	sabbiato anodizzato/nero	36 Raggi D3,5 ecoc zinc	sabbiato anodizzato/nero	36 Raggi D3,5 ecoc zinc	sabbiato anodizzato/nero	36 Raggi D3,5 ecoc zinc	sabbiato anodizzato/nero	36 Raggi D3,5 ecoc zinc	sabbiato anodizzato/nero		
	36 Niplo STS M4.		36 Niplo STS M4.		36 Niplo STS M4.		36 Niplo STS M4.		36 Niplo STS M4.		36 Niplo STS M4.		36 Niplo STS M4.			
REAR	code N° 6 KA	code N° W6-50	code N° 13 SU	code N° W7-50	code N° 20 HN	code N° W8-50	code N° 27 YA	code N° W9-50	code N° 34 AP	code N° X1-50	code N° 41 HU	code N° S2-50	code N° 48 KT	code N° X2-50		
	Per Mod. KX-F	Cerchio 177/5,0"	Per Mod. RM-Z	Cerchio 177/5,0"	Per Mod. CR-F	Cerchio 177/5,0"	Per Mod. WR-F e YZ-F	Cerchio 177/5,0"	Per Mod. SXV	Cerchio 177/5,0"	Per Mod. SM	Cerchio 177/5,0"	Per Mod. SX-F e EXC-F	Cerchio 177/5,0"		
MOTARD	36 Raggi D4 ecoc zinc	sabbiato anodizzato/nero	36 Raggi D4 ecoc zinc	sabbiato anodizzato/nero	32 Raggi D4 ecoc zinc	sabbiato anodizzato/nero	36 Raggi D4 ecoc zinc	sabbiato anodizzato/nero	36 Raggi D4 ecoc zinc	sabbiato anodizzato/nero	36 Raggi D4 ecoc zinc	sabbiato anodizzato/nero	36 Raggi D4 ecoc zinc	sabbiato anodizzato/nero		
	36 Niplo STS M4,5		36 Niplo STS M4,5		32 Niplo STS M4,5		36 Niplo STS M4,5		36 Niplo STS M4,5		36 Niplo STS M4,5		36 Niplo STS M4,5			
REAR	code N° 6 KA	code N° W6-55	code N° 13 SU	code N° W7-55	code N° 20 HN	code N° W8-55	code N° 27 YA	code N° W9-55	code N° 34 AP	code N° X1-55	code N° 41 HU	code N° S2-55	code N° 48 KT	code N° X2-55		
	Per Mod. KX-F	Cerchio 177/5,5"	Per Mod. RM-Z	Cerchio 177/5,5"	Per Mod. CR-F	Cerchio 177/5,5"	Per Mod. WR-F e YZ-F	Cerchio 177/5,5"	Per Mod. SXV	Cerchio 177/5,5"	Per Mod. SM	Cerchio 177/5,5"	Per Mod. SX-F e EXC-F	Cerchio 177/5,5"		
MOTARD	36 Raggi D4 ecoc zinc	sabbiato anodizzato/nero	36 Raggi D4 ecoc zinc	sabbiato anodizzato/nero	32 Raggi D4 ecoc zinc	sabbiato anodizzato/nero	36 Raggi D4 ecoc zinc	sabbiato anodizzato/nero	36 Raggi D4 ecoc zinc	sabbiato anodizzato/nero	36 Raggi D4 ecoc zinc	sabbiato anodizzato/nero	36 Raggi D4 ecoc zinc	sabbiato anodizzato/nero		
	36 Niplo STS M4,5		36 Niplo STS M4,5		32 Niplo STS M4,5		36 Niplo STS M4,5		36 Niplo STS M4,5		36 Niplo STS M4,5		36 Niplo STS M4,5			
FRONT													code N° 50 KT	code N° U1	code N° 52 TR	code N° W0
													Per Mod. 990 ADV	Cerchio 217/2,15"	Per Mod. Thruxton	Cerchio 187/2,50"
													36 Raggi D5/3,9 Cromati	sabbiato anodizzato/nero	36 Raggi D5/3,9 Cromati	sabbiato/anodizzato/nero
													36 Niplo STS M4,5		36 Nipples STS M4,5	
															code N° 53 TR	code N° X3
															Per Mod. Scrambler-Boneville	Cerchio 197/2,50"
ALLROAD															36 Raggi D5/3,9 Cromati	sabbiato anodizzato/nero
															36 Nipples STS M4,5	
REAR													code N° 51 KT	code N° U2	code N° 54 TR	code N° X0
ALLROAD													Per Mod. 990 ADV	Cerchio 187/4,25"	Per Mod. Boneville - Scrambler -Thruxton	Cerchio 177/3,50"
													36 Raggi D5/3,9 Cromati	sabbiato anodizzato/nero	40 Raggi D5/3,9 Cromati	sabbiato anodizzato/nero
													36 Niplo STS M4,5		40 Nipples STS M4,5	

uzuki_KTM_990_Adventure_2006_05_1024x768.jpg



Husovarna Cross





ktm 990 adventure





CHANGE



THE KIT CONSIST OF:

- 36 + 36 ALPINA CHROME PLATED SPOKES
- 36 + 36 ALPINA STS NIPPLES

OPTIONAL:

- RIM SET SAND BLASTED ANODIZED
- 36 + 36 COLOURED JACKETS

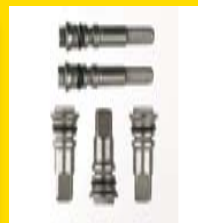

YOUR MIND

alpina TUBELESS STS



KIT TUBELESS STS ALPINA AVAILABLE X KTM 990 ADVENTURE

alping TUBELESS STS

Con l'applicazione di nipples modificati GARANTISCE:
The application of the modified nipple GUARANTEES:

- 1) Sicurezza e modernità di una ruota tubeless
A secure and modern tubeless wheel
- 2) Semplicità dovuta dall'utilizzo degli stessi mozzi, cerchi e raggi già in uso.
Simple handling by using the same hubs, rims and spokes.
- 3) Economicità grazie all'utilizzo dalle stesse macchine e metodologie di assemblaggio
Economic efficiency by using the same assembling machineries and methodologies.

ASSEMBLAGGIO CON STS ASSEMBLING WITH STS



Cerchio con Raggio e Nipples
+ guarnizione OR e Anello di Sicurezza

Rim with Nipples and Spokes
+ O-ring and Retaining Ring

Anello di arresto / Retaining ring

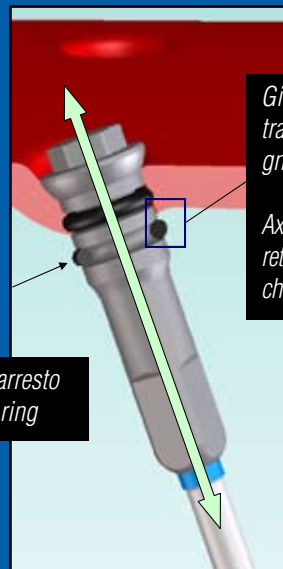

Gioco in direzione assiale
tra anello di arresto e bu-
gna del cerchio

Axial clearance between
retaining ring and the pun-
ching hole of the rim

Anello di arresto
Retaining ring

O-ring

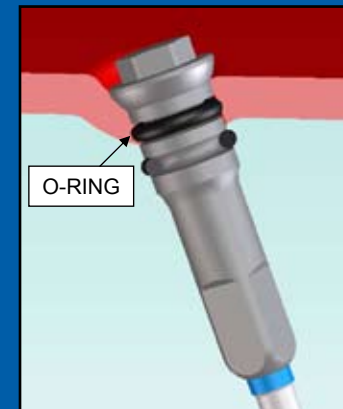

O-RING

SPECIFICHE O-RING O-Ring specifications

OR qualita standard OR standard quality

Materiale elastomero NBR
Material Elastomer NBR

Resistenza termica: -30°C÷+100°C
Thermal resistance: -30°C÷+100°C

Compatibilità chimica con idrocarburi
Chemical compatibility with hydrocarbons

Compressione standard (P≈35 bar) ≈ 15÷30%
Standard compression (P≈35 bar) ≈ 15÷30%

STS compressione≈ 15÷20%
STS compression ≈ 15÷20%

Cerchio / Rim

Disegno foro valvola del cerchio adatto per applicazione tubeless
The drawing of the valve hole in the rim fits for tubeless applications

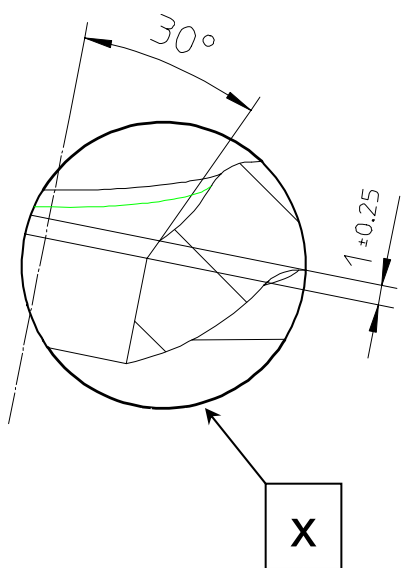

DISASSAMENTO CONSENTITO TRA ASSE FORO DIAM. 9 E CENTRO BUGNA PARI A 0.5mm.

MAXIMAL MISALIGNMENT ALLOWED BETWEEN DIAMETER 9 HOLE AXIS AND CENTER OF THE PUNCHING HOLE IS 0.5mm

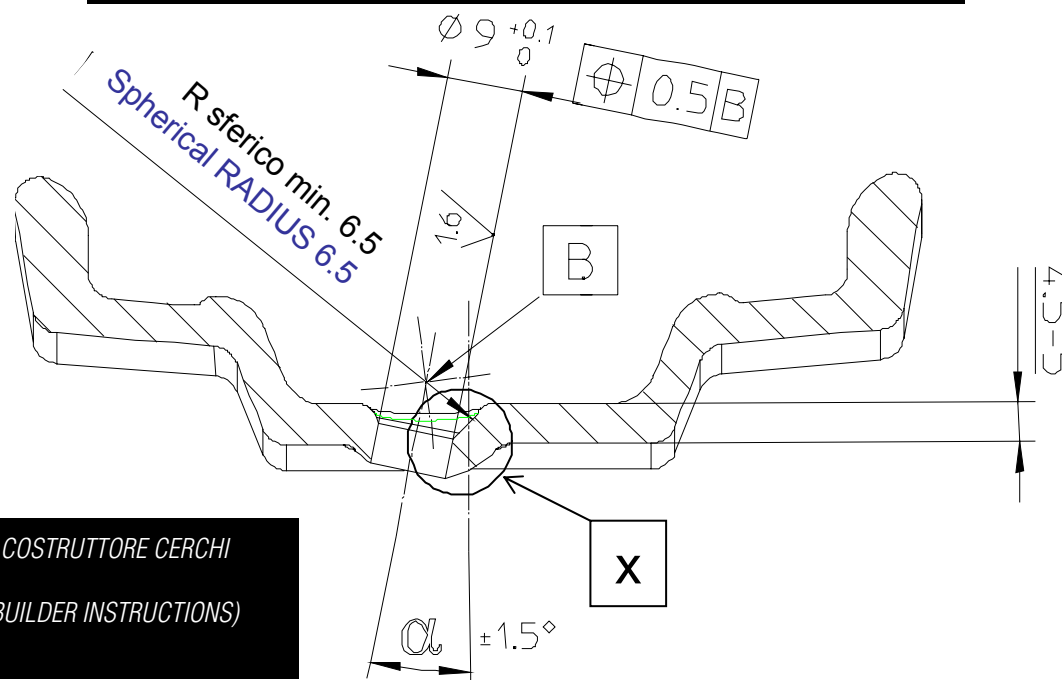

INCLINAZIONI MASSIME ESEGUIBILI SECONDO DIRETTIVE COSTRUTTORE CERCHI
 MAX. INCLINATION POSSIBLE (CORRESPONDING TO RIM BUILDER INSTRUCTIONS)

alpina TUBELESS STS**IL PESO DI STS / WEIGHT OF STS**

Scegliendo di montare il sistema sts di alpina, si ottiene una ruota tubeless con un peso di CIRCA - 600 GRAMMI (F.) e - 900 GRAMMI (R.) rispetto ad una ruota tradizionale con camera d'aria.

Mounting the sts system of alpina, you can obtain a tubeless wheel by loosing - 600 GRAMS (F.) and - 900 GRAMS (R.) of weight in comparison with a set of tube type wheels.

PER RUOTA TRADIZIONALE CON CAMERA AD ARIA

36 NIPPLES M 4.5 = Gr. 245+
 1 CAMERA D'ARIA= Gr. 620 (F.) / Gr. 920 (R.)
 FLAP= Gr. 100
 TOTALE = GRAMMI 965 (F.) / 1265 (R.)

PER RUOTA TUBELESS CON NIPPLES STS

36 NIPPLES STS M 4.5 = Gr. 365+
 ASSENZA DI CAMERA D'ARIA / SENZA FLAP
 TOTALE = GRAMMI 365

RISULTATO: GRAMMI 965 (F.) / 1265 (R.) - 365 = GRAMMI 600 (F.) / 900 (R.)
 RISPARMIO DI PESO CON STS

ALPINA CONCLUSIONI: CON STS SI RISPARMIANO CIRCA 600 GRAMMI (RUOTA ANTERIORE) E 900 GRAMMI (RUOTA POSTERIORE) SULLA MASSA ROTANTE ESTERNA

FOR TRADITIONAL TUBE TYPE WHEEL

36 NIPPLES M 4.5 = Gr. 245+
 1 AIR TUBE = GGr. 620 (F.) / Gr. 920 (R.)
 FLAP= Gr. 100
 TOTAL = GRAMS 965 (F.) / 1265 (R.)

FOR STS NIPPLES TUBELESS WHEEL

36 NIPPLES STS M 4.5 = Gr. 365+
 NO AIR TUBE / WITHOUT FLAP
 TOTAL = GRAMS 365

THAT MEANS: 965 (F.) / 1265 (R.) - 365 = 600 (F.) / 900 (R.) GRAMS
 SAVING OF WEIGHT BY USING STS ALPINA

CONCLUSIONS: WITH ALPINA STS YOU SAVE 600 GRAMS (FRONT WHEEL) AND 900 GRAMS (REAR WHEEL) ON THE EXTERNAL ROTATING BULK

Conclusioni / Conclusion

- *Il sistema STS di Alpina, Standard Tubeless System e' un brevetto rivolto a chi desidera migliorare le PRESTAZIONI e la SICUREZZA della ruota raggiata. L'eliminazione della camera d'aria la rende piu' TECNOLOGICA e COMPETITIVA grazie anche ad un notevole risparmio di peso (circa 1,5 kg sulla coppia di ruote)*
- *ALPINA STS, Standard Tubeless System, is a patent for everyone who wants to improve the quality and the SAFETY of spoked wheels. By eliminating the air tube, the wheel becomes more TECHNOLOGICAL and COMPETITIVE, thanks to a remarkable save of weight (1,5 kg for each wheels set)*

Look, Performance

Coming soon!



alping



alping CARBONPROTM MATRIX

TUBELESS RAGGI&CARBONIO

CARBONPRO™ MATRIX

TUBELESS SYSTEM CARBON&SPOKES





alpina

07_08
CATALOGUE

alpina

ALPINA RAGGI S.p.A.
Via Piave, 10 - 23871
LOMAGNA (Lecco) Italia
Tel. + 39 039 92281
Fax + 39 039 9220294

mail: info@alpinaraggi.it
web: www.alpinaraggi.it